



G 440 XT 8X4 TIPPER

20.2 CU.M ROCK BODY



SCANIA

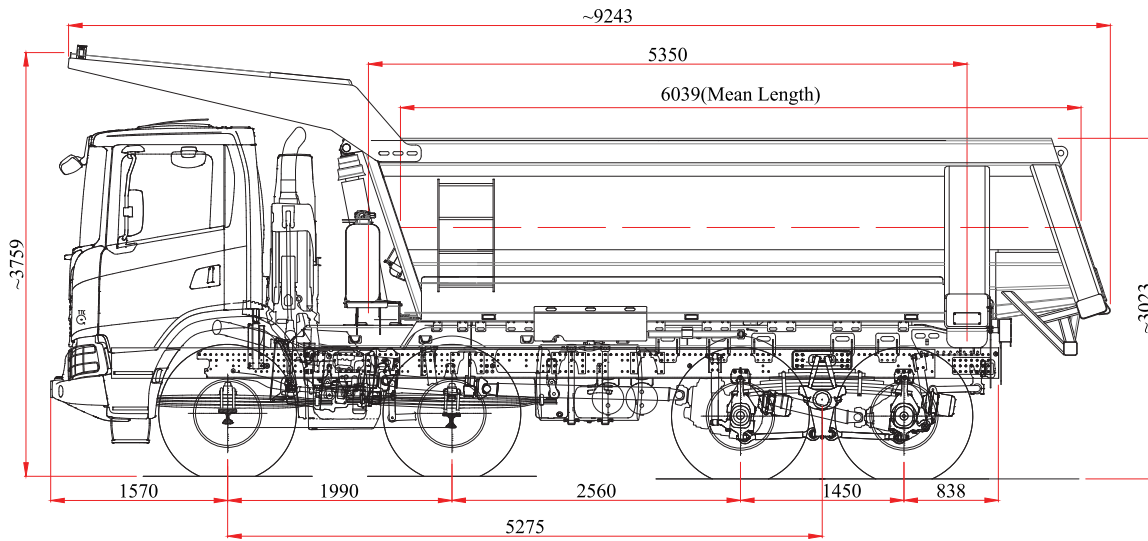

All dimensions are in mm

G 440 XT 8X4 TIPPER - 20.2 CU.M ROCK BODY

DIMENSIONS

| | |
|---------------------|----------|
| Wheel base..... | 5,275 mm |
| Overall length..... | 9,243 mm |
| Overall width..... | 2,600 mm |
| Overall height..... | 3,759 mm |
| Bogie distance..... | 1,450 mm |

WEIGHTS

LADEN CHASSIS WEIGHT WITH BODY (As per CMVR)

| | |
|-----------------|-----------|
| Front axle..... | 14,000 kg |
| Rear axle..... | 21,000 kg |
| Total | 35,000 kg |

ENGINE DC13 151 / 440 hp

| | |
|--------------------------|------------------------------|
| Type..... | Inline Engine |
| No. of Cylinders..... | 6 Cylinders |
| Engine Displacement..... | 12.7 litres |
| Max. Power..... | 440 hp @ 1,900 rpm |
| Max. Torque... .. | 2,300 Nm @ 1,000 - 1,300 rpm |
| Injection system... .. | Unit PDE Injection System |
| Emission norms..... | Euro 4 / BS IV |

CLUTCH

| | |
|----------------------------|-------------------------|
| Clutch Type..... | Single dry plate clutch |
| Clutch Actuation..... | Electro hydraulic |
| Clutch plate Diameter..... | 430 mm |

GEARBOX GRS0925

| | |
|-----------------------------|--|
| Type..... | Range Splitter gearbox with Overdrive |
| Gear shift program..... | Scania opticruise with lay shaft brake |
| No. of Gears..... | 14F + 2R |
| Crawler Gear..... | 2 Numbers |
| Oil cooler for Gearbox..... | Liquid cooled oil cooler |

FUEL TANK

| | |
|---------------|-----------------|
| Type..... | Steel Fuel tank |
| Capacity..... | 380 L |

SUSPENSION

FRONT

| | |
|---------------------------|--|
| Type..... | Parabolic |
| No. of leaf springs | 4 no's with heavy duty hydraulic shock absorbers and Anti roll bar |

REAR

| | |
|---------------------------|--------------------------------------|
| Type..... | Trapezoidal bogie suspension |
| No. of leaf springs | 8 no's with heavy duty Anti roll bar |

AXLES

FRONT

Forged I beam reverse Elliot high mounted axle

REAR

Tandem bogie axle with Hub reduction Ratio 7.63:1

BRAKES

Dual circuit pneumatic drum brakes
Automatic Slack adjusters
Anti lock braking system
Traction control system
Manual & Automatic exhaust brake control

TYRES & RIMS

Wheel rim..... Steel disc type
Rim Size..... 8.5 x 24
Tyre Size..... 12x24, 18PR
One complete spare wheel rim and tyre provided

ELECTRICAL SYSTEM

| | |
|-----------------------|----------|
| Voltage..... | 2 x 12 V |
| Battery Capacity..... | 140 Ah |
| Alternator..... | 100 A |

STEERING SYSTEM

Hydraulic power assisted steering wheel
Steering wheel dia..... 450 mm
Pneumatically Adjustable Steering wheel
Angle..... 0-52 degrees
Height..... 80 mm

CABIN CG 14L

INTERIORS

Air Conditioned Cabin
Engine hour meter Analogue
Instrument Cluster features
• Fuel consumption display
• Trip meter
• PTO hour Indicator
• Engine hour Indicator
• Idle hour Indicator
• Scania Driver support system
• Auto engine shutdown

EXTERIORS

Tinted Windscreen
Heavy duty steel bumper - 40 Ton
4 point suspension
End outline Marker lamps

TIPPER BODY

Option 1: U Body for Overburden*

| | |
|---------------------------------------|--------------|
| Volume..... | 20.2 Cu.m |
| Mean length..... | 6,039 mm |
| Width..... | 2,258 mm |
| Height..... | 1,582 mm |
| Body Material..... | Hardox 450 |
| Tipping angle..... | 51 degrees |
| Hydraulic cylinder ¹ | Hyva FE169-4 |
| Oil tank capacity..... | 110 L |

Option 2: Box Body for Infrastructure

| | |
|---------------------------------------|-------------------|
| Volume..... | 22 Cu. m |
| Mean length..... | 5,690 mm |
| Width..... | 2,400 mm |
| Height..... | 1,640 mm |
| Body Material..... | Steel 450 N / mm2 |
| Tipping angle..... | 50 degrees |
| Hydraulic cylinder ¹ | Hyva FE157-4 |
| Oil tank capacity..... | 80 L |

* Rock Body available in cladded option

¹ Hydraulic Kit options available

Scania CV India Pvt Ltd
Plot No. 64-66, Narsapura
KIADB Industrial Area,
Achhatanahalli Village,
Narsapura Hobli, Taluk/District - Kolar,
Karnataka - 563 133, India
Website : www.scania.com
Tel : +91 80-8152288300

L&T Construction & Mining Machinery
Larsen & Toubro Limited
Lakshminarayan Complex (1st Floor)
10/1 Palace Road,
Bangalore - 560 052
Tel : 080 4040 1700 / 1813
Tel : 080 2225 0309
Email : pro.psd@larsentoubr.com

Edition 2019.07 ref001 @ Scania CV IN

Note : The specifications / images shown here are indicative and are subject to change without prior notice

SCANIA