



# **XMOR 21.5 m<sup>3</sup> MINING TIPPER**

TIPPER BODY MADE IN HARDOX® WEAR PLATE

## **SERVICE AND MAINTENANCE**

# Table of Contents

<b>1. General Description</b> .....	3
1.1. Scope .....	3
1.2. Service and Maintenance Interval .....	3
1.3. Preparations .....	3
1.4. In Case of Damage to the Tipper Body.....	3
<b>2. Safety Information Definitions</b> .....	4
<b>3. Plate Damage Inspection</b> .....	5
<b>4. Visual Weld Inspection</b> .....	6
4.1. Inside Welds.....	6
4.2. Side Welds .....	7
4.3. Canopy Welds .....	7
4.4. Front Welds .....	8
4.5. Pivot Beam Welds.....	8
4.6. Rear Welds .....	9
4.7. Bottom Welds.....	9
4.8. Subframe Welds.....	10
4.9. Tailgate and cable .....	11
<b>5. Hydraulic kit inspection with, service and maintenance checklist</b> .....	12
<b>6. Lamp Inspection</b> .....	15
6.1. Rear Lamps.....	15
6.2. Side Marker Lamps .....	15
<b>7. Electrical Wiring Inspection</b> .....	16
<b>8. Bolt Inspection</b> .....	16
8.1. Subframe attachment bolts .....	16
8.2. Cylinder Cradle Mounting Brackets Bolts .....	19
8.3. Wood or Rubber and Bolts .....	19
8.4. Mudflap Plate Bolts.....	20
<b>9. Lubrication</b> .....	21
9.1. Pivot Axle Lubrication .....	21
9.2. Body Tilt Support Lubrication .....	22
9.3. Stabilizer assembly lubrication.....	22
9.4. Tipping cylinder lubrication .....	23
9.5. Mechanical Body clamp lubrication .....	23
9.6. Tail gate arm lubrication and hinge shaft.....	24

# 1. GENERAL DESCRIPTION

## 1.1. Scope

This document describes the service and maintenance procedure of the XMOR 21.5 m<sup>3</sup> Mining Tipper.

This document does not describe how to repair the tipper body.

## 1.2. Service and Maintenance Interval

The tipper body must undergo maintenance once per week.

A full service and maintenance procedure is recommended in case of sudden damage to the tipper body.

## 1.3. Preparations

The following preparations are required before the start of the service and maintenance procedure:

- Clean the tipper body thoroughly with a high pressure washer.
- Print the XMOR 21.5 m<sup>3</sup> Mining Tipper Service and Maintenance Checklist and use it to track and report progress during the service and maintenance procedure.



## 1.4. In Case of Damage to the Tipper Body

All tipper body damage must be reported to the supplier of the product.

## 2. Safety Information Definitions

Safety awareness reduces risk of injury and damage to personnel, equipment and parts.

This document uses the following definitions for safety information:

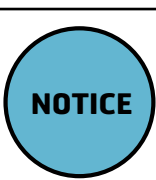
 <b>DANGER</b>	<ul style="list-style-type: none"><li>• A danger statement indicates a hazardous situation that, if not avoided, will result in death or serious injury.</li></ul>
 <b>WARNING</b>	<ul style="list-style-type: none"><li>• A warning statement indicates a hazardous situation that, if not avoided, could result in death or serious injury.</li></ul>
 <b>CAUTION</b>	<ul style="list-style-type: none"><li>• A caution statement indicates a hazardous situation that, if not avoided, could result in minor or moderate injury.</li></ul>
 <b>NOTICE</b>	<ul style="list-style-type: none"><li>• A notice indicates information considered important but not hazard related.</li></ul>

### 3. Plate Damage Inspection

This chapter describes the inspection of the plates that are exposed to impact wear when loading as well as sliding wear when unloading.

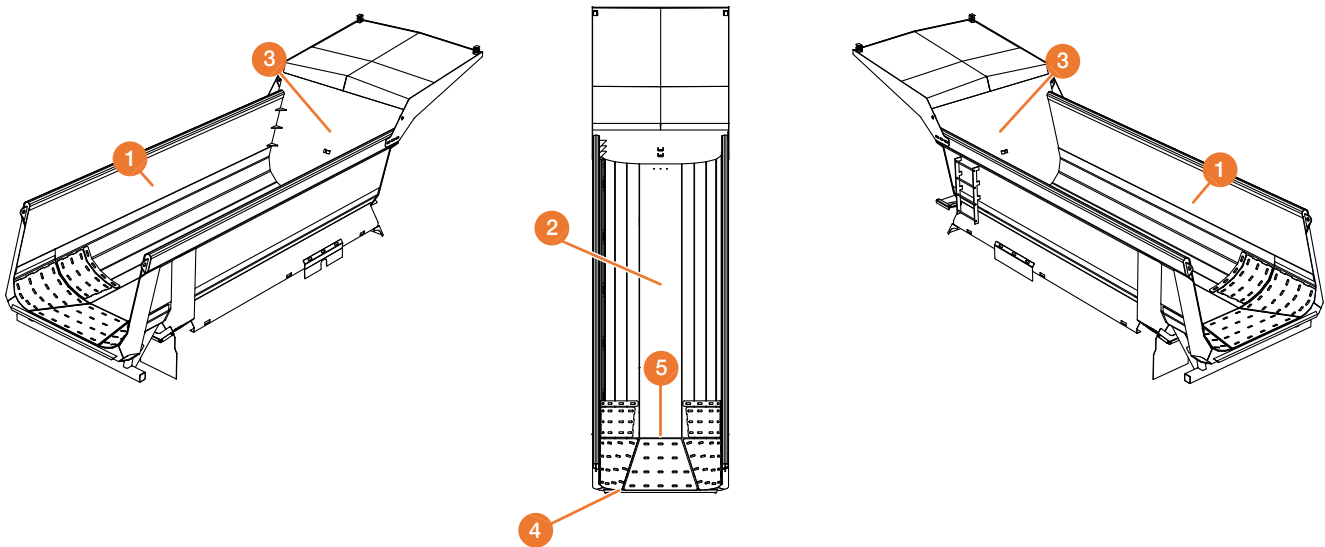

- a) Inspect the Side plates on the tipper body for dents, cracks and holes (Pos 1.).
- b) Inspect the Bottom plate on the tipper body for dents, cracks and holes (Pos 2.).
- c) Inspect the Front plate on the tipper body for dents, cracks and holes (Pos 3.).
- d) Inspect the Chute plate on the tipper body for dents, cracks and holes (Pos 4.).
- e) Inspect the Liner plates on the tipper body for dents, cracks and holes (Pos 5.).

Recurring relining is required to maintain the quality and lifespan of a tipper body in operation.

In case any of the Liner plates is severely damaged or has fallen off it shall be replaced in order to maintain the quality and lifespan of the tipper body in operation

Ensure that the Bottom and Chute plate has not been worn down below half the original thickness before relining.

In case of damage (excluding normal wear and tear) to the tipper body plates or need for relining, contact the supplier of the product.

 <p><b>NOTICE</b></p>	<ul style="list-style-type: none"> <li>• Dents can cause an increased wear rate and shorten the lifespan of the tipper body</li> <li>• Wear rate is dependent on number of unloads and abrasiveness of handled material</li> <li>• Use the tipper body according to the operating instructions</li> </ul>
--	---

## 4. Visual Weld Inspection

This chapter describes the location of the welds on the tipper body and subframe that must be visually inspected.

Cracks or other problems related to the welds must be noted in the XMOR 21.5 m<sup>3</sup> Mining Tipper Service and Maintenance Checklist and reported.

### 4.1. Inside Welds

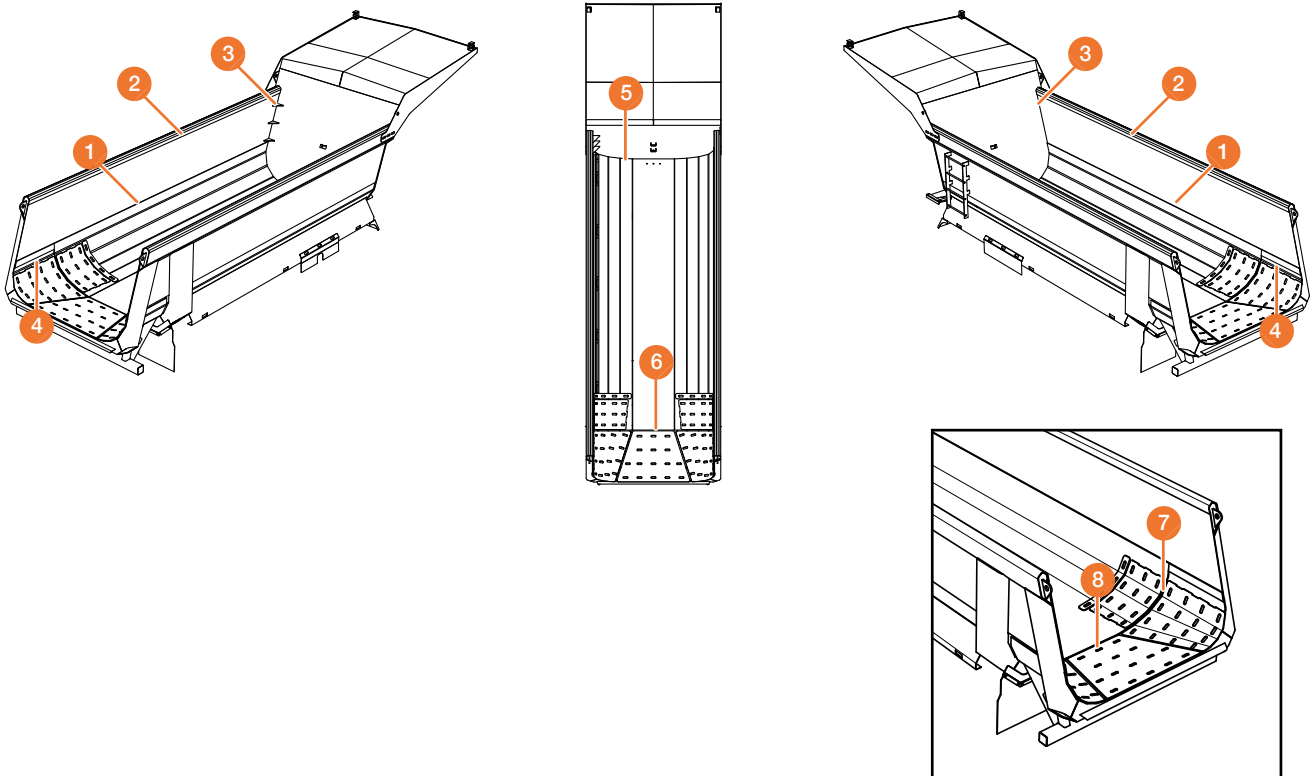

- a) Inspect the weld between the Side Plate and the Bottom Plate on both sides of the tipper body (Pos. 1).
- b) Inspect the weld between the Side Plate and the Top Line on both sides of the tipper body (Pos. 2).
- c) Inspect the weld between the Side Plate and the Front Plate on both sides of the tipper body (Pos. 3).
- d) Inspect the welds around the Bottom Cover Plate on both sides of the tipper body (Pos. 4).
- e) Inspect the weld between the Bottom Plate and the Front Plate (Pos. 5).
- f) Inspect the weld between the Bottom Plate and the Chute Plate (Pos. 6).
- g) Inspect the welds between Lining plate and Bottom plate (pos 7).
- h) Inspect the welds between Lining plate and Chute plate (pos 8).

## 4.2. Side Welds

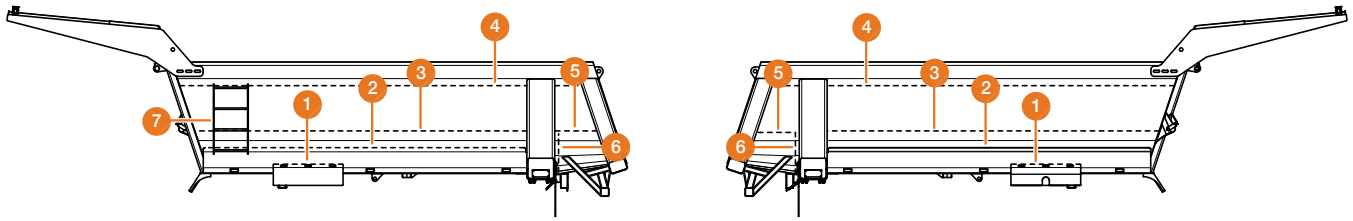

- a) Inspect the weld between the Air Tank Guard and the Side Skirt on both sides of the tipper body (Pos. 1).
- b) Inspect the weld between the Side Skirt and the Bottom Plate on both sides of the tipper body (Pos. 2).
- c) Inspect the weld between the Bottom Plate and the Side Plate on both sides of the tipper body (Pos. 3).
- d) Inspect the weld between the Side Plate and the Top Line on both sides of the tipper body (Pos. 4).
- e) Inspect the weld between the Chute Plate and the Side Plate on both sides of the tipper body (Pos. 5)
- f) Inspect the weld between the Bottom Plate and the Chute Plate on both sides of the tipper body (Pos. 6).
- g) Inspect the welds between the Ladder and the tipper body (Pos. 7).

## 4.3. Canopy Welds

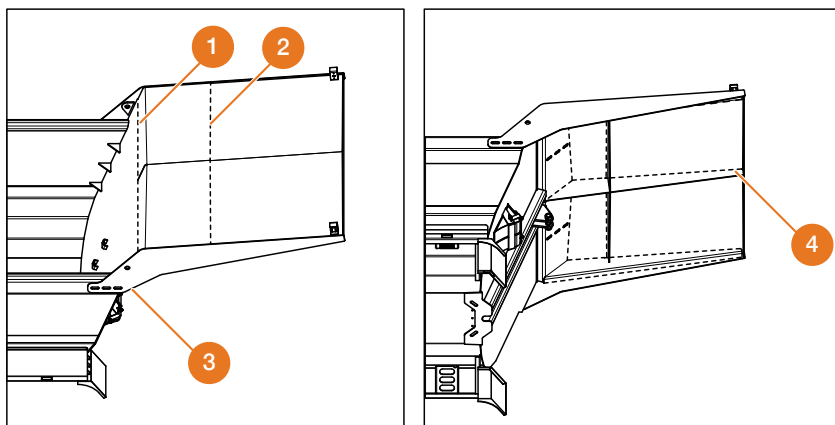

- a) Inspect the weld between the Canopy and the Front Plate (Pos. 1).
- b) Inspect the weld on the top of the Canopy (Pos. 2).
- c) Inspect the welds between the Canopy, the Front Wall and the Top Lines (Pos. 3).
- d) Inspect the welds on the bottom of the Canopy (Pos. 4).

### 4.4. Front Welds

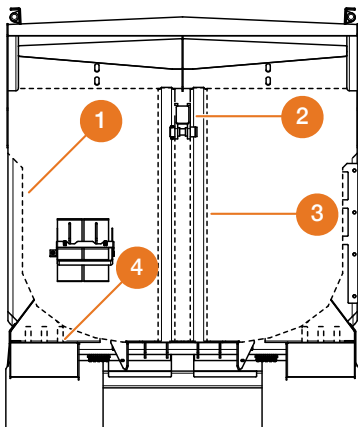

- a) Inspect the welds around the Front Wall (Pos. 1).
- b) Inspect the welds on the Tipping Cylinder Attachment (Pos. 2).
- c) Inspect the welds on the Reinforcement Beams (Pos. 3).
- d) Inspect the welds on the Mudguard on both sides of the tipper body (Pos. 4).

### 4.5. Pivot Beam Welds

 <b>WARNING</b>	<ul style="list-style-type: none"> <li>• Do not work under an unstable tipper body.</li> <li>• Risk of crush injuries.</li> <li>• Use the tilt support if the tipper body is tilted.</li> </ul>
---	---

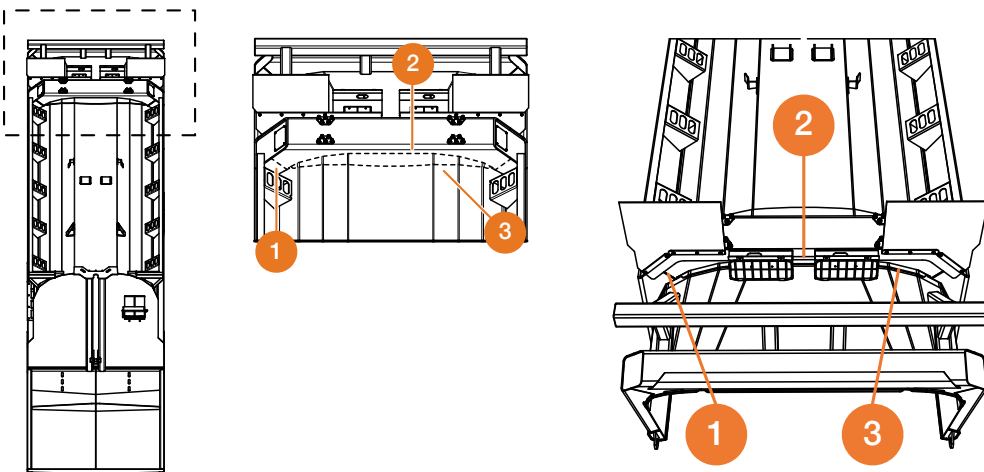

- a) Inspect the welds on the Pivot Beam (Pos. 1).
- b) Inspect the welds between the Pivot Beam and the Tipper Body (Pos. 2).
- c) Inspect the welds on the Saddle Plate (Pos. 3).



## 4.6. Rear Welds

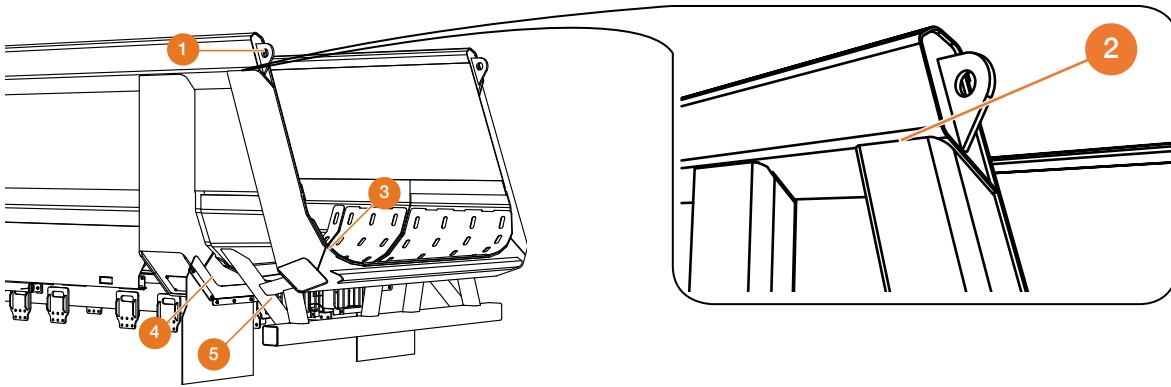

- Inspect the weld between the Lifting Ear and the Top Line on both sides of the Canopy if applicable (Pos. 1).
- Inspect the weld between the Rear Beam and the Top Line (Pos. 2).
- Inspect the welds on the Rear Beam (Pos. 3).
- Inspect the weld between the Fastening Plate Mudflaps and Pivot Beam on both sides of the tipper body (Pos. 4).
- Inspect the welds on the Underrun Protection (Pos. 5).

## 4.7. Bottom Welds

 <p><b>WARNING</b></p>	<ul style="list-style-type: none"> <li>• Do not work under an unstable tipper body.</li> <li>• Risk of crush injuries.</li> <li>• Use the tilt support if the tipper body is tilted.</li> </ul>
---	---

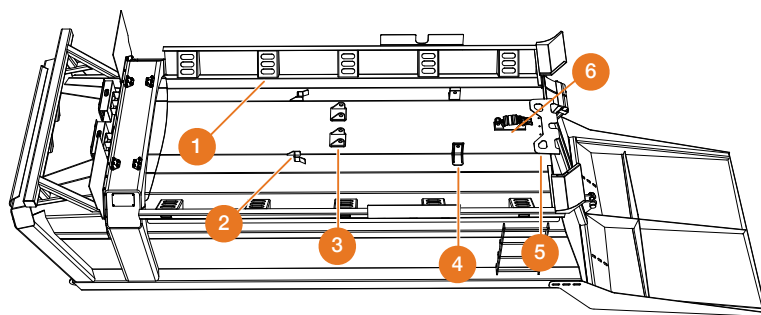

- Inspect the weld between the Side Skirt Assembly and the Bottom Plate on both sides of the tipper body (Pos. 1).
- Inspect the welds on the two Supporting Rod Brackets (Pos. 2).
- Inspect the welds on the two Stabilizer Brackets (Pos. 3).
- Inspect the welds on the two Guiding Bracket Assemblies (Pos. 4).
- Inspect the welds between the Reinforcement Plate and the Bottom Plate (Pos. 5).
- Inspect the welds between the Mechanical body clamp and the Bottom Plate (Pos. 6).

## 4.8. Subframe Welds

 <p><b>WARNING</b></p>	<ul style="list-style-type: none"> <li>• Do not work under an unstable tipper body.</li> <li>• Risk of crush injuries.</li> <li>• Use the tilt support if the tipper body is tilted.</li> </ul>
---	---

The Chassis frame, Subframe and reinforcements work together to withstand the loads that may occur during operation.

Inspect the welds in each area below. Also check for possible misalignment. There should not be any cracks in the plates or the welds. If any deviations such as cracks or similar note down in what area they are observed, record the quantity and the length and take a picture of the crack itself and also the surrounding area of the structure.

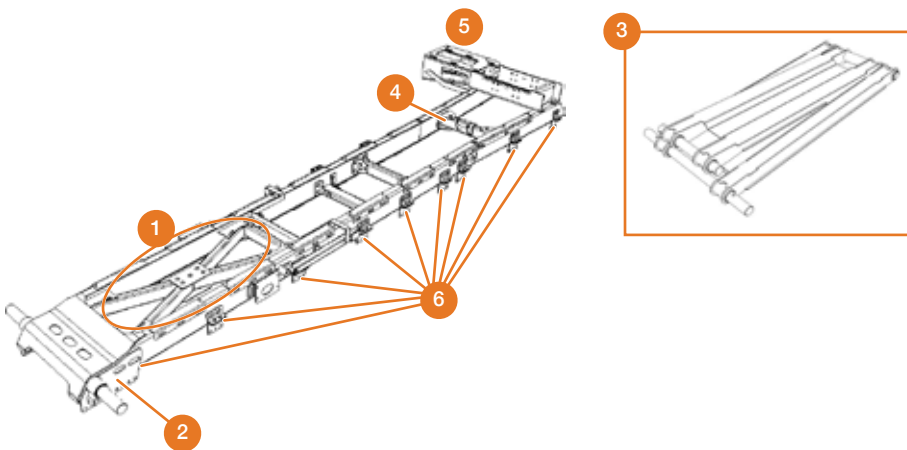

- Inspect the weld of the Rear Cross Member (Pos. 1).
- Inspect the weld of the Rear Hinge Area as well as the Pivot Brackets (Pos. 2).
- Inspect the welds of the Stabilizer assembly (Pos. 3).
- Inspect the welds of the Hyfix Cross member and 2nd Cross member (Pos. 4).
- Inspect the welds of the Cradle bracket (Pos. 5).
- Inspect the welds of the attachment plates and attachment brackets (Pos. 6).

## 4.9. Tailgate and cable

 <p><b>WARNING</b></p>	<ul style="list-style-type: none"> <li>• Do not work under an unstable tipper body.</li> <li>• Risk of crush injuries.</li> <li>• Use the tilt support if the tipper body is tilted.</li> </ul>
---	---

The Chassis frame, Subframe and reinforcements work together to withstand the loads that may occur during operation.

Inspect the welds in each area below. Also check for possible misalignment. There should not be any cracks in the plates or the welds. If any deviations such as cracks or similar note down in what area they are observed, record the quantity and the length and take a picture of the crack itself and also the surrounding area of the structure.

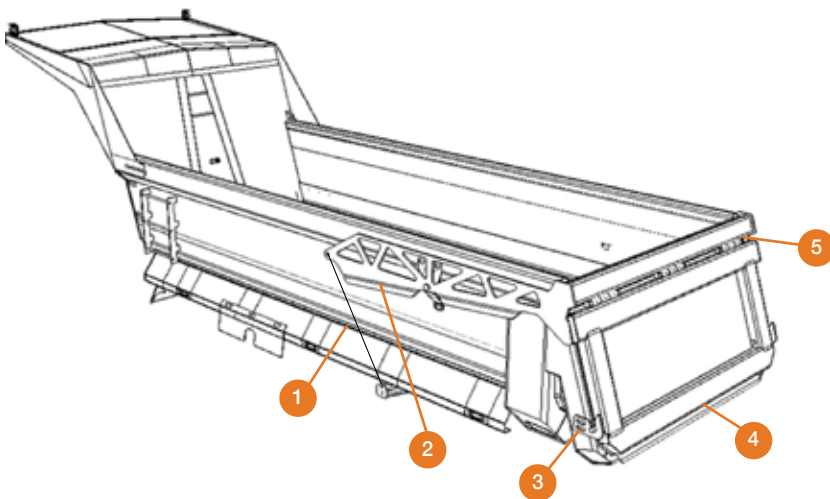

- Inspect the cable length and attachments (Pos. 1).
- Inspect the lifting arm. Straightness and damages (Pos. 2).
- Inspect the locking hooks and pin (Pos. 3).
- Inspect the welds of the tailgate. No gaps between tailgate and body (Pos. 4).
- Inspect the welds of the attachment plates and attachment brackets (Pos. 5).

## 5. Hydraulic kit inspection with, service and maintenance checklist

Inspection of Hydraulic kit and related components should always be carried out according to supplier service and maintenance manuals. The below is an overview only of what needs to be done for most Hydraulic systems.

Keep all elements of the Hydraulic system clean and eliminate all leaks immediately. Do not clean the hydraulic system using steam, high pressure water or caustic chemicals. Do not make any modifications to the Hydraulic system. For hydraulic oil recommendations refer to document OIL-0011. If the document isn't available, please contact your nearest Hyva service partner or visit our website ([www.hyva.com](http://www.hyva.com)). Equivalent oils from other suppliers can be used.

Keep all elements of the Pneumatic system clean and eliminate all leaks immediately. Do not clean the hydraulic system using steam, high pressure water or caustic chemicals. Do not make any modifications to the pneumatic system.

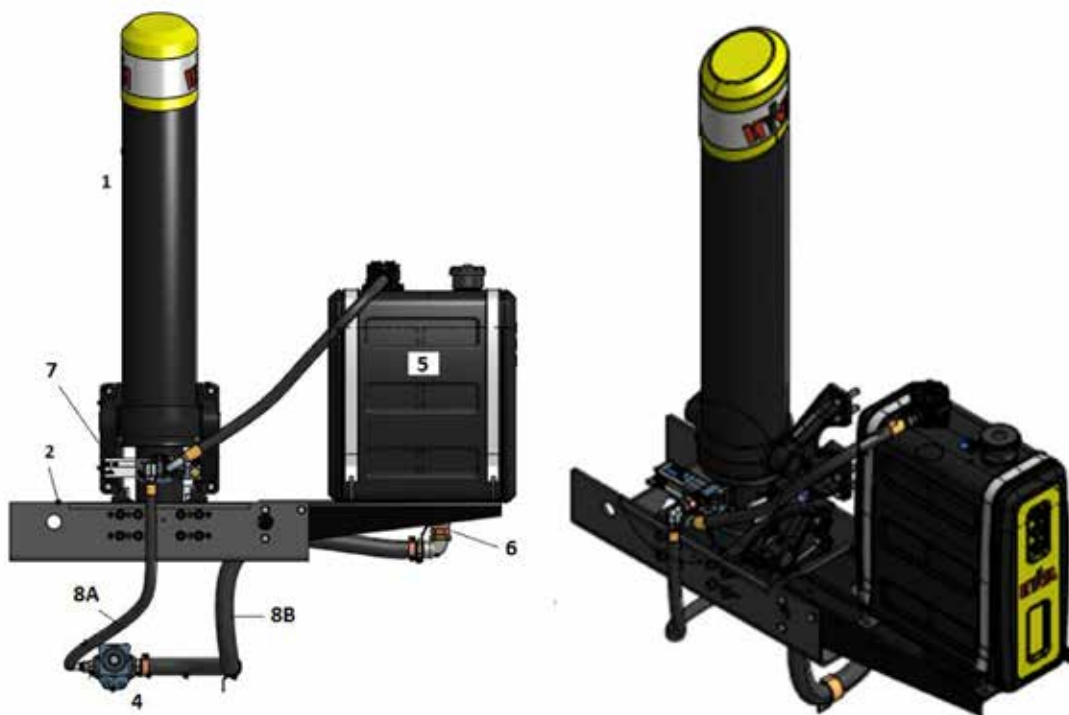

Maintenance Intervals	Ref.	Service Task	Status
<b>Daily</b>	6.1	Check air hoses: damages & leaks	_____
	6.2	Check knock-off: operation, damages & leaks	_____
	6.3	Check air control: operation, damages & leaks	_____
	6.4	Check cylinder (1): operation, damages & leaks	_____
	6.5	Check hydraulic hoses (2A, B, C): damages & leaks	_____
	6.6	Check Hydraulic valve (3): damages & leaks	_____
	6.7	Check Tank (4): damages & leaks	_____
	6.8	Check oil level in the oil tank. Oil level has to be in the middle of the spy eye or level indicator, while body is resting on the sub frame.	_____
	6.9	Grease chassis brackets (8) of cylinder	_____
	6.10	Grease piston eye on tipper body	_____
	6.11	Grease rear hinges of body (the right amount of grease has been added when the newly applied grease can be visually seen between the sleeves. Visually inspect to ensure the above).	_____
	6.12	Grease tail door mechanism and and hinges	_____
	6.13	Grease Hyfix body clamp	_____
	6.14	Grease Stabilizer pivot points	_____
<b>Weekly</b>	6.15	Clean outside of cylinder (1)	_____
	6.16	Check "leak indicator" hole of pump (5)	_____
	6.17	Check oil return filter (6)	_____
	6.18	Check air breather filter (7)	_____
	6.19	Check nut and bolt (torques)	_____
<b>Every 2 months</b>	6.20	If the hydraulic oil is dirty or contaminated, drain and clean the oil tank (and the hoses) and fill with new oil.	_____
	6.21	Change oil return filter	_____
	6.22	Change air breather filter	_____
<b>Annually</b>	6.23	Change oil and make sure tank is clean	_____
	6.21	Change oil return filter	_____
	6.22	Change air breather filter	_____

(1) DO NOT use a steam cleaner when cleaning hydraulics. When using pressurized cleaner, temperature should be below 40°C.

(2) Greasing for lubrication is only required regularly in greased bearings. Hyva maintenance free bearings require grease for easy installation and not for lubrication. Suitable types of grease are: Hyva packset grease, Molykote G-4500, Dinitrol Paste and Shell Ensys.

Please find below, detailed BOM list and Drawing of Hydraulic parts.

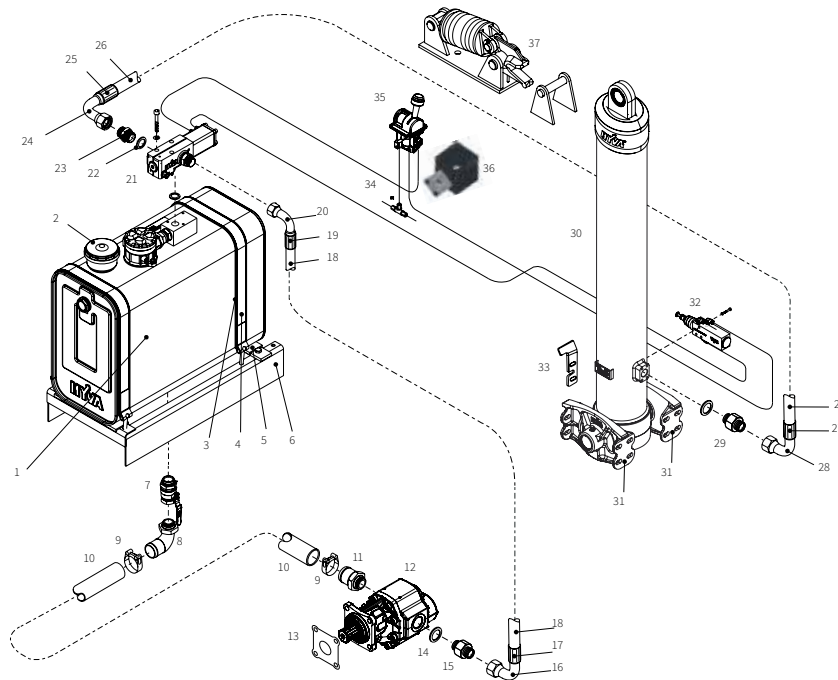

Pos.	Part no.	Description	Qty.	Pos.	Part no.	Description	Qty.
<b>Oil tank parts consisting of:</b>				<b>Valve parts consisting of:</b>			
1	14016300	Oil tank cm-100 l/079 l-mp-rf	1	21	14767125	Tip valve ht-tnk-1220-250-p1"	1
2	08102116	Filler/breather assembly complete	1	22	01313848	Bonded seal 1"	1
3	14020040	Rubber 1175 x 40 mm	2	23	01222661	Adaptor hp - 3/4" "bspotc 3/4"	1
4	14020030	Strap 1200 x 40 mm	2	<b>Hose parts - valve to cylinder:</b>			
5	14020070	Rubber cm tank support 141/162	2	24	14787850	Coupling hose 90-sw-hose 3/4"-3/4" bspit	1
6	14020090	Tank support 149 (286) strap mounted tank	1	25	14787800	Ferrule hose 3/4" hp hyva standard (2 sh)	1
7	14780981	Ball valve 1 1/2" bspot+nut - 1 1/2" bsp	1	26	14790001	Hose 3/4"-hp-12 roll of 31m 280 bar	3.1 m
8	14799050A	Hose pillar 90 1 1/2" - lp28 + nut alu	1	27	14787800	Ferrule hose 3/4" hp hyva standard (2sh)	1
<b>Suction hose parts consist of:</b>				28	14787850	Coupling hose 90-sw-hose 3/4"-3/4" bspit	1
9	14796600	Hose clip for lp28 reinforced	2	<b>Cylinder parts consisting of:</b>			
10	14795120	Hose 1 3/4"-lp-28-02000	1	29	14799080	Adaptor hp 00 1" bspotc x 3/4" bspotc	1
<b>Pump parts consisting of:</b>				30	70136390	Fe a157-4-05105-011-k1599-hd	1
11	14799005A	Hose pillar 00 1 1/4" - lp28 alu	1	31	01506136	Chassis bracket 368-d60 hd-gr-t45 mach.	2
12	14562036	Gear pump 113l-bi-4h5-4p-20bsp20-250	1	32	14700575	Knock-off valve pneumatic hd incl. Mk	1
13	14624850	Gasket for iso 4-h pump	1	33	75375015	Stop plate knock off mk2	1
14	01206874	Bonded seal 1 1/4"	1	<b>Tip control parts consistng of:</b>			
15	01317959	Adaptor hp 00 1 1/4" bspotc x 3/4" bspotc	1	34	14750119k	Air tube kit pto/valve ctrl - 6 mm/25 m	2
<b>Hose parts - pump to valve</b>				35	14750667h	Tip control-air-ts/lf	1
16	14787850	Coupling hose 90-sw-hose 3/4"-3/4" bspit	1	36	02119105	Support bracket tip control 25 mm handle	1
17	14787800	Ferrule hose 3/4" hp hyva standard (2 sh)	1	<b>Body components parts consistng of:</b>			
18	14790001	Hose 3/4"-hp-12 roll of 31m 280 bar	2 m	37	08102855	Hyfix-set steel including bracket	1
19	14787800	Ferrule hose 3/4" hp hyva standard (2 sh)	1				
20	14787860	Coupling hose 90-sw-hose 3/4"-1" bspit	1				

## 6. Lamp Inspection

### 6.1. Rear Lamps

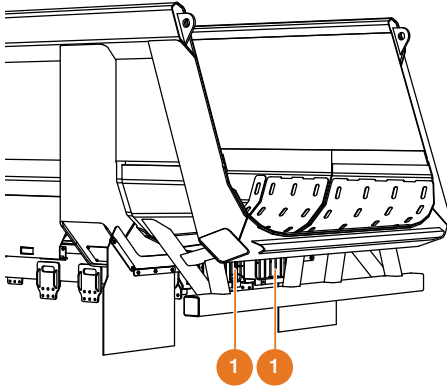

a) Inspect the Rear Lamps for damage and verify that they are functioning (Pos. 1).

### 6.2. Side Marker Lamps

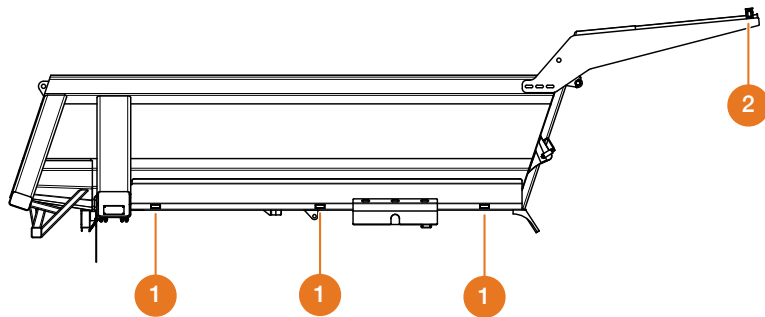

a) Inspect the Side Marker Lamps on both sides of the tipper body for damage and verify that they are functioning (Pos. 1).

b) Inspect the Canopy Lamps on both sides of the tipper body for damage and verify that they are functioning (Pos. 2).

## 7. Electrical Wiring Inspection

 <p><b>WARNING</b></p>	<ul style="list-style-type: none"> <li>• Do not work under an unstable tipper body.</li> <li>• Risk of crush injuries.</li> <li>• Use the tilt support if the tipper body is tilted.</li> </ul>
---	---

- a) Inspect the wiring to the Rear Lamps, Side Marker Lamps and Canopy Lamps for damage and verify that they are in position.

## 8. Bolt Inspection

### 8.1. Subframe attachment bolts

The attachment between the Subframe and the Chassis frame is designed to allow certain movement. The size of the movement depends on driving conditions, operating behavior as well as torsional rigidity of the subframe and the body. It is critical that the attachment bolts and springs are maintained on a weekly basis. This section describes the procedure to make sure that all bolts have required torque.

 <p><b>WARNING</b></p>	<ul style="list-style-type: none"> <li>• Do not work under an unstable tipper body.</li> <li>• Risk of crush injuries.</li> <li>• Use the tilt support if the tipper body is tilted.</li> </ul>
---	---

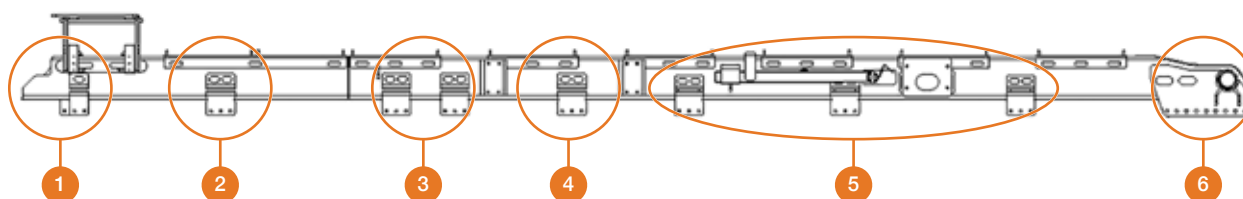

- a) This section describes to make sure that there are no bolts are missing or loose and bolts are having required torque or not.
- b) Inspect the bolted joints between the subframe and chassis and make sure that no bolts are missing/ loose/ damaged and all the bolts are tightened as mentioned torque as per below images.



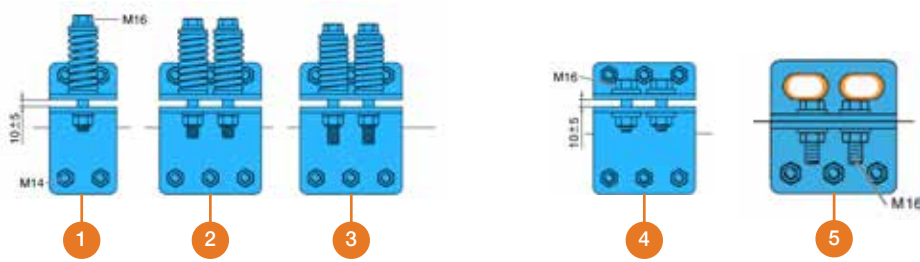

### 1) First Attachment bracket

Check the M14 bolt Torque and Spring Flexibility.

- Apply the Torque for M14 bolt 135 Nm
- Tighten M16 Bolt and press the spring Fully together and loosen 15 mm. (Weekly basis)

### 2) Second Attachment bracket (Check the M14 bolt Torque and Spring Flexibility.)

- Apply the Torque for M14 bolt 135 Nm
- Tighten M16 Bolt and press the spring Fully together and loosen 10 mm. (Weekly basis)

### 3) Third Attachment bracket

Check the M14 bolt Torque and Spring Flexibility.

- Apply the Torque for M14 bolt 135 Nm
- Tighten M16 Bolt and press the spring Fully together and loosen 5 mm. (Weekly basis)

### 4) Fourth Attachment bracket

Check the M14 bolt Torque and Spring Flexibility.

- Apply the Torque for M14 bolt 135 Nm
- Tighten M16 Bolt and press the spring Fully together and loosen 5 mm. (Weekly basis)

### 5) Fifth Attachment bracket

Check the M14 bolt Torque and Spring Flexibility.

- Apply the Torque for M14 bolt 135 Nm
- Tighten M16 Bolt and press the spring Fully together and loosen 5 mm. (Weekly basis)

### 6) Attachment plates

Check the M14 bolt Torque.

- Apply the Torque for M16 bolt 270 Nm (Weekly basis)

**WARNING**

- Do not work under an unstable tipper body.
- Risk of crush injuries.
- Use the tilt support if the tipper body is tilted.

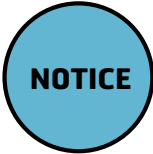
**NOTICE**

- Do not tighten the bolts between the Pivot Axle Hinge and Pivot Beam if they are tight.
- Risk of damage to bolt threads.
- Use hand to feel if the bolts are tight.

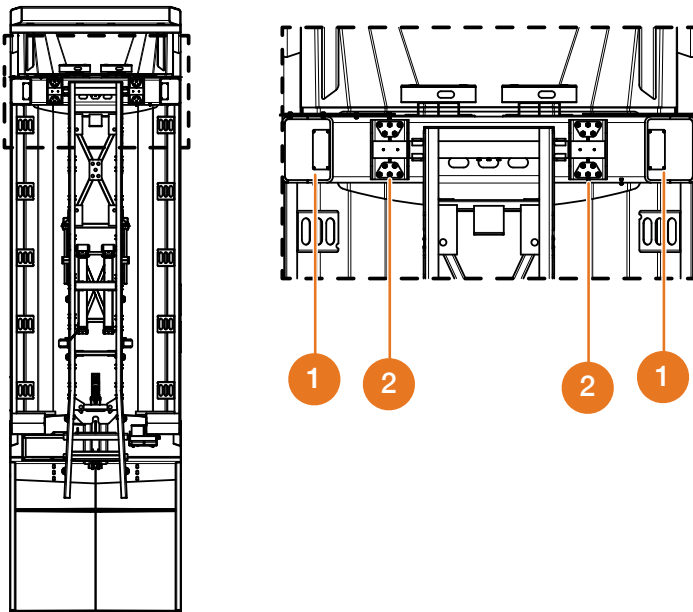

- Inspect the bolts on the Pivot Beam Lids on both sides of the tipper body for damage. Verify that no bolts are missing (Pos 1).
- Inspect the bolts between the Pivot Beam and the Pivot Axle Hinge for damage (Pos. 2). Verify that no bolts are missing.
- Use a hand to feel if the bolts between the Pivot Beam and Pivot Axle need to be tightened. If a bolt needs to be tightened, use a torque wrench to apply a force of 330 Nm to the bolt from the outside of the Pivot Beam and use a wrench on the inside of the Pivot Beam to hold the bolt back.

## 8.2. Cylinder Cradle Mounting Brackets Bolts

 <p><b>WARNING</b></p>	<ul style="list-style-type: none"> <li>• Do not work under an unstable tipper body.</li> <li>• Risk of crush injuries.</li> <li>• Use the tilt support if the tipper body is tilted.</li> </ul>
---	---

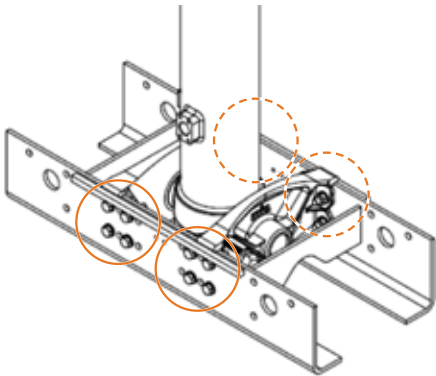

- Inspect the bolts (16 units) on the Cylinder Cradle Mounting Bracket for damage. Verify that no bolts are missing.
- If a bolt needs to be tightened, use a torque wrench to apply a force of 225 Nm to the bolt from the outside of the Cradle bracket and use a wrench on the inside to hold the bolt back.

## 8.3. Wood or Rubber and Bolts

 <p><b>WARNING</b></p>	<ul style="list-style-type: none"> <li>• Do not work under an unstable tipper body.</li> <li>• Risk of crush injuries.</li> <li>• Use the tilt support if the tipper body is tilted.</li> </ul>
---	---

This section describes to make sure no bolts are missing or loose and bolts are having required torque or not. Make sure that the wood/rubber of the subframe is intact.

- Tip the tipper body. Inspect the wood between the subframe and tipper body. (weekly basis)
- Lower the tipper body to neutral position. Check that there are no cracks or pieces missing in the wood, if any observed, replace with new piece of wood. Make sure no bolts missing or loosening, If bolt is missing provide the new bolt and nut. If Loosening apply the torque 24 Nm. (weekly basis)

## 8.4. Mudflap Plate Bolts

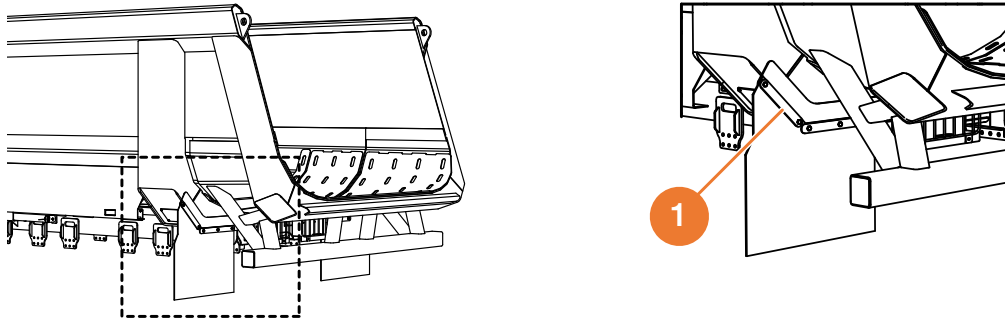

a) Inspect the Mudflap Plate bolts for damage (Pos. 1). Verify that no bolts are missing and that they are tightened.

## 9. Lubrication

This chapter describes where the tipper body and subframe requires lubrication.

Place the nozzle of the grease gun at the grease nipple. Apply the specified grease or similar.

The needed amount of grease depends on the interval since the last lubrication.

Use Shell Gadus S3 V1000A or similar as lubrication.

### 9.1. Pivot Axle Lubrication



**WARNING**

- Do not work under an unstable tipper body.
- Risk of crush injuries.
- Use the tilt support if the tipper body is tilted.

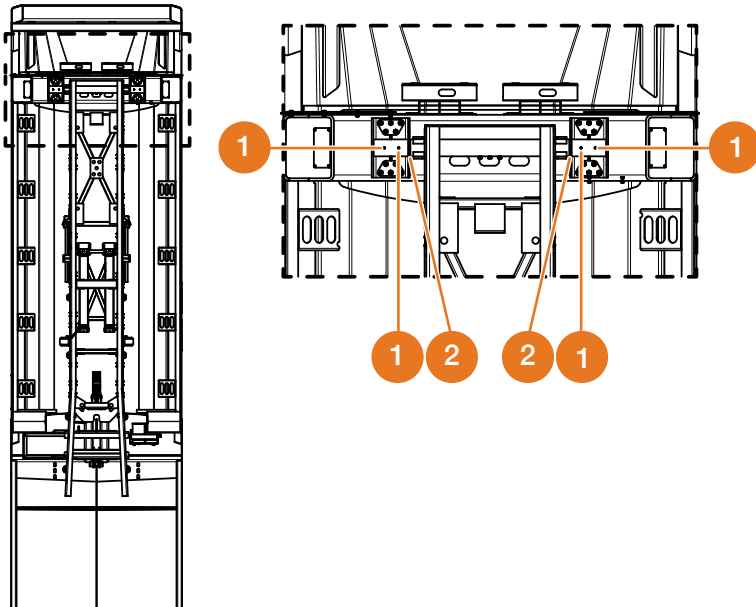

- Lubricate the four grease nipples (type AM8) on the Pivot Axle (Pos. 1).
- The right amount of grease has been added when the newly applied grease can be visually seen between the sleeves. Visually inspect to ensure the above (Pos. 2).

### 9.2. Body Tilt Support Lubrication

 <p><b>WARNING</b></p>	<ul style="list-style-type: none"> <li>• Do not work under an unstable tipper body.</li> <li>• Risk of crush injuries.</li> <li>• Use the tilt support if the tipper body is tilted.</li> </ul>
---	---

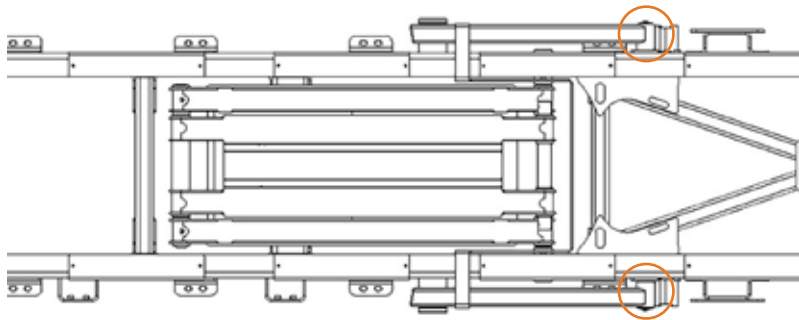

a) Lubricate the two grease nipples (type AM8) on the Body Tilt Support arm as depicted with circle.

### 9.3. Stabilizer assembly lubrication

 <p><b>WARNING</b></p>	<ul style="list-style-type: none"> <li>• Do not work under an unstable tipper body.</li> <li>• Risk of crush injuries.</li> <li>• Use the tilt support if the tipper body is tilted.</li> </ul>
---	---

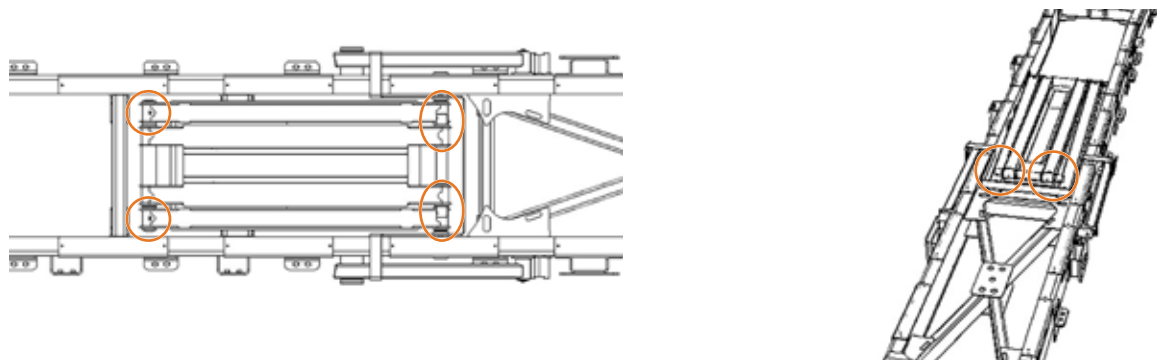

a) Greasing to be perform six places in Stabilizer assembly as mentioned in the image with circles.

## 9.4. Tipping cylinder lubrication

 <p><b>WARNING</b></p>	<ul style="list-style-type: none"> <li>• Do not work under an unstable tipper body.</li> <li>• Risk of crush injuries.</li> <li>• Use the tilt support if the tipper body is tilted.</li> </ul>
---	---

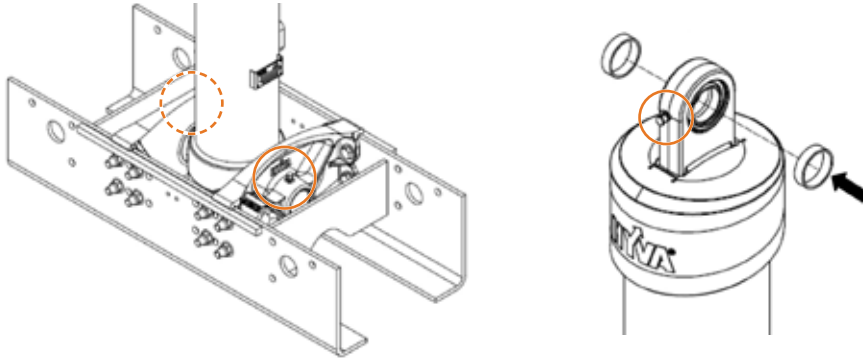

- Greasing to be performed on each side of the hydraulic cylinder mounting brackets, see image with circle
- Grease piston eye on hydraulic cylinder, see image with circle.

## 9.5. Mechanical Body clamp lubrication

 <p><b>WARNING</b></p>	<ul style="list-style-type: none"> <li>• Do not work under an unstable tipper body.</li> <li>• Risk of crush injuries.</li> <li>• Use the tilt support if the tipper body is tilted.</li> </ul>
---	---

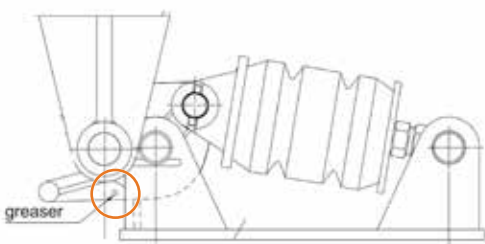

- Grease Hyfix body clamp as mentioned in the below image with circle.
- Check condition of power block and compression rod.

## 9.6. Tail gate arm lubrication and hinge shaft

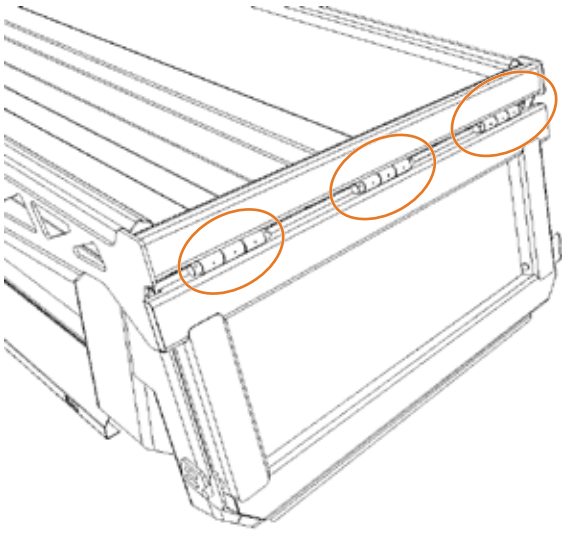

c) Grease Tail gate hinge mechanism on nine positions, in the image marked with circles.











With the objective to change the mind-set of the earth-moving industry, XMOR™ provide premium products with unique and innovative designs to revolutionize excavation, loading and hauling. XMOR™ delivers the most productive products in the mining and earth moving industry that take full advantage of the latest Hardox materials. The combination of using the world's best steels, with optimized design and the highest quality production processes, makes it possible to reduce weight and offer larger products with higher payloads than their counterparts; increasing the productivity of your assets and reducing your cost per ton. In short, with XMOR you can expect more in less time.

XMOR™ buckets and bodies can be fitted to virtually any OEM equipment, which means you can swap out existing buckets and bodies and start saving immediately. Or if buying new equipment you can in many cases go down one machine size and still produce as much as earlier. XMOR™ products are made available globally by carefully selected and highly qualified licensed partners with extensive experience.

**SSAB EMEA AB**  
SSAB EMEA AB  
SE-613 80, Oxelösund  
Sweden

Phone: +46 155 25 40 00  
Fax: +46 155 25 40 73

[partner.support@xmor.info](mailto:partner.support@xmor.info)  
[www.xmor.info](http://www.xmor.info)

*Manufactured under license from SSAB EMEA AB  
XMOR™ is a trademark owned by the SSAB Group of companies*